

ECT Electric Connector Technology CO.,LTD 深圳市电连精密技术有限公司	Product Specification	DOC. No.: 651-0071-01	Rev.: F	Page: 1/4
	PART No.:	Approved/Date	Checked/Date	Made/Date
	ECT818000071	Henry 03/19/11'	Henry 03/19/11'	SAM 03/19/11'

1、Scope(简述)

The product described in this paper is a SMT Type Micro Coaxial RF Receptacle, whose part name in our comply is USS RF REC..It is special for Microstrip-to-Coaxial adapter in RF circuit, Such as Mobile Phone, Wireless Net, MiniPCI, Bluetooth, PDA, GPS, Electric Measurement Instruments and so on.

本产品为超小表面贴装 (USS RF), 适用于 RF 电路微带同轴传输转接口, 应用于移动电话, 无线网络, 袖珍型 PCI, 蓝牙, 掌上电脑, 全球定位系统, 电子测量仪器, 等等

2、Technical Parameters(技术参数)

2.1 Rated Voltage(额定电压)	60VAC (R. M. S)
2.2 Frequency Range(频率范围)	0~6GHz
2.3 Character Impedance(特性阻抗)	50Ω
2.4 Operate Temperature(工作温度)	-40°C ~ +90°C
2.5 Operate Humidity(工作湿度)	90% MAX

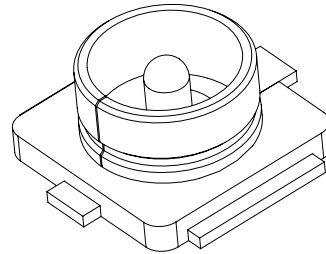

3、Electric Performance(电性能)

3.1 Dielectric Resistance(绝缘阻抗)	500MΩ
3.2 Dielectric Withstand Voltage(耐电压)	200V AC
3.3 Contact Resistance(接触阻抗)	
3.3.1 Inner Contact(内导体)	Initial(初始) : 20 mΩ max After(测试后) : 25 mΩ max
3.3.2 Outer Contact(外导体)	Initial(初始) : 10 mΩ max After(测试后) : 15 mΩ max

3.4 VSWR(电压驻波比)

≦ 3GHz	3-6GHz
1.2 max	1.3 max

3.4.1 Test Method(测试方法):

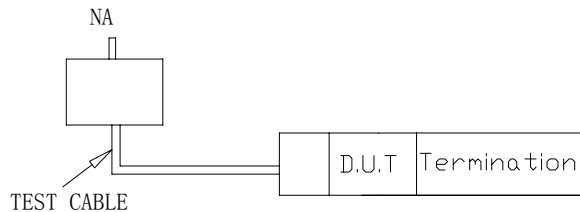

4、Mechanical Performance(机械性能)

4.1 Durability(寿命)	100 Cycles
4.2 Shock(冲击)	Accerlaration: 735m/s ² , 11ms (Time), Waveform: Half-wave waveform, 6 Cycles In Each X-Y-Zaxis 加速度: 735m/s ² , 11ms (时间), 波形: 半正弦波, 3个轴向各6个循环
4.3 Vibration(振动)	Frequency: 10-100Hz, single amplitude of 1.5mm, acceleration of 59m/s ² . for 5cycles in the direction of each of the 3axis. 频率: 10-100Hz, 单向幅度 1.5mm, 加速度: 59m/s ² , 3个轴向各 5 个循环

ECT Electric Connector Technology CO.,LTD 深圳市电连精密技术有限公司	Product Specification	DOC. No.: 651-0071-01	Rev.: F	Page: 2/4
	PART No.:	Approved/Date	Checked/Date	Made/Date
	ECT818000071	Henry 03/19/11'	Henry 03/19/11'	SAM 03/19/11'

5、Environment Performance (环境性能)

5.1 Temperature & Humidity Cycling (稳态湿热) TEM.: 60°C Relative Humidity: 95% RH Time: 96 hours
 温度: 40°C 湿度: 95% RH 时间: 96 hours

5.2 Salt spray (盐雾试验) Temp.: 35°C Conduction: 5% Time: 48 hours
 温度: 35°C 浓度: 5% 时间: 48 hours

5.3 Solderability (可焊性) The Sn Immersed Area must beyond by 95%.
 吃锡面积 95%以上

6、SMT Temperature Curve (SMT 温度曲线图)

6.1 Recommended tem.&time relative curve of Re-flow.
 建议回流焊温度与时间条件

6.2 Extremed tem.&time curve of Re-flow
 回流焊极限温度与时间条件

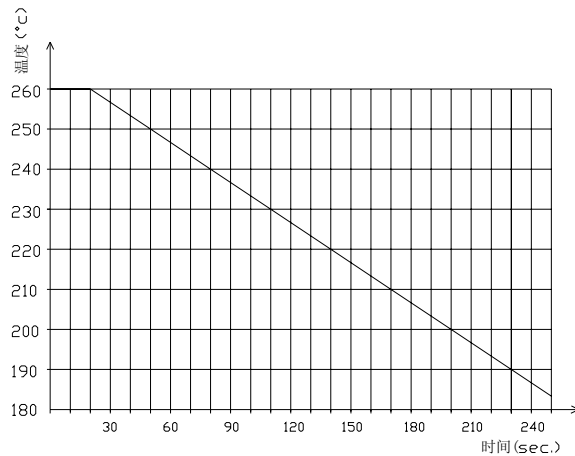
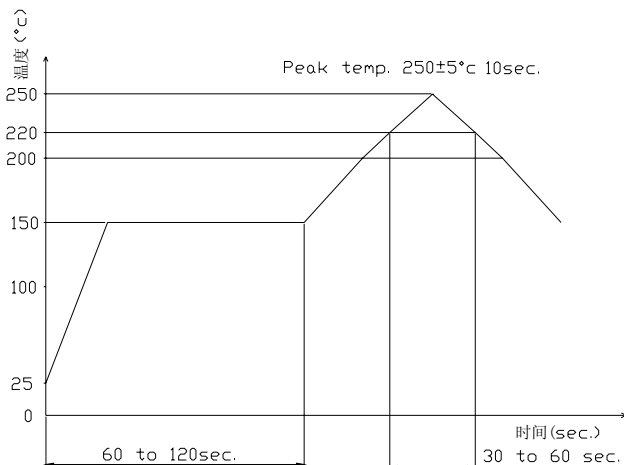

7、Profile Dimensions (外形尺寸)

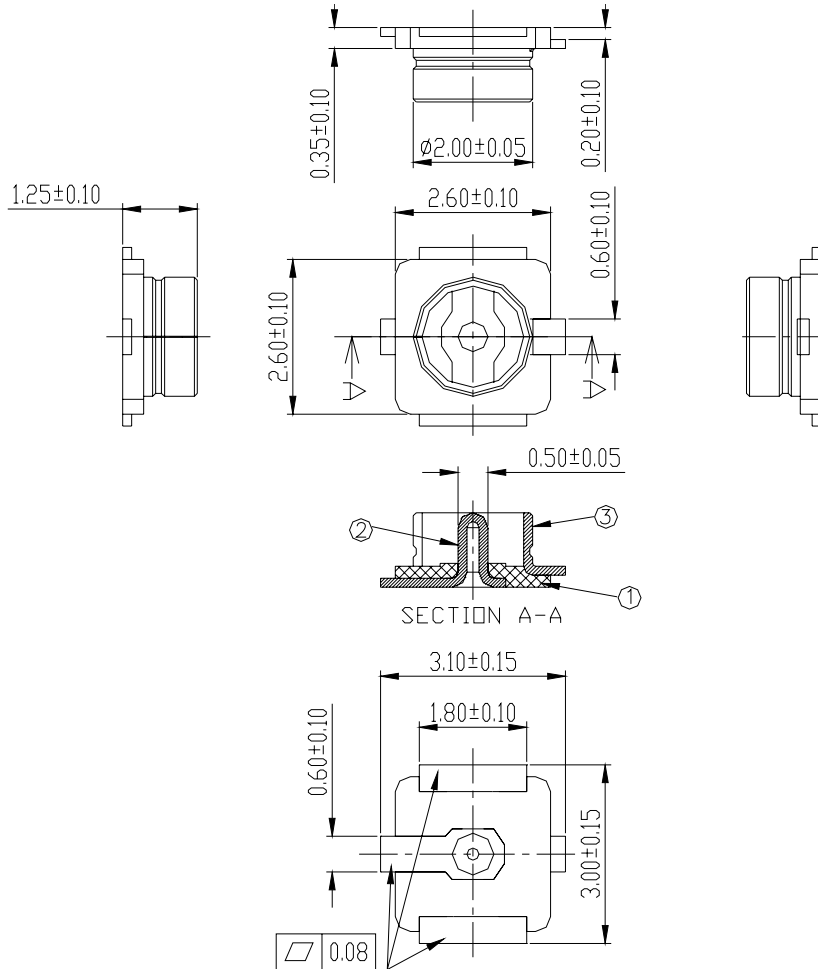

③	SHELL	1	COPPER ALLOY/Ag PLATED OVER Ni
②	CONTACT	1	COPPER ALLOY/GOLD PLATED OVER Ni
①	HOUSING	1	HIGHT TEMP. PLASTIC UL94V-0/BLACK
ITEM	PART NAME	Q'TY	MATERIAL/FINISH

8、PCB LAYOUT

